

#PA BC "	D5FHBI A 69F	89G7 F-DHC B	E HM
%	D' \$\$) &(\$.'*!' &L '%#&"D< @D5 B 'H5DHH9 G#G 6@5 7 ?	&
&	D' \$%) \$!((+D	8@#HI B 3 9FG5 @'@' 6F 5 7 ?9H	%
'	D' \$\$) (!&'	.'%\$ L) #, 'D< @@DG D5 B ZHMD9) Z((\$%G#G	&
(D' \$\$- &I +	.'*!' &5 7 C FB!@C K ' 7 F C K B 'G#G 6@5 7 ?	&
)	D' \$\$&(!&(+L+ 'DC @M65;	%
*	D@5 6&%L &K <=	? #I@5 69@	%
+	D@#() (6?H	B GF I 7 HC B	%

BCHG-CK B
 5
 6

F9J "	97 F	89G7 F-DHC B	85H9
!	%) %&	B #H5 @8F5K B; F 9E I 9GH	\$(#)% #6
5	% * , ,	#PA ' .) D' \$\$&(!&(' K 5GD' \$\$&(!%*	+ #98/#&\$%*
6	% , , (F 9A C J 98 I G5 ' @5 69@D@5 6I G5 H	- #&- #7*

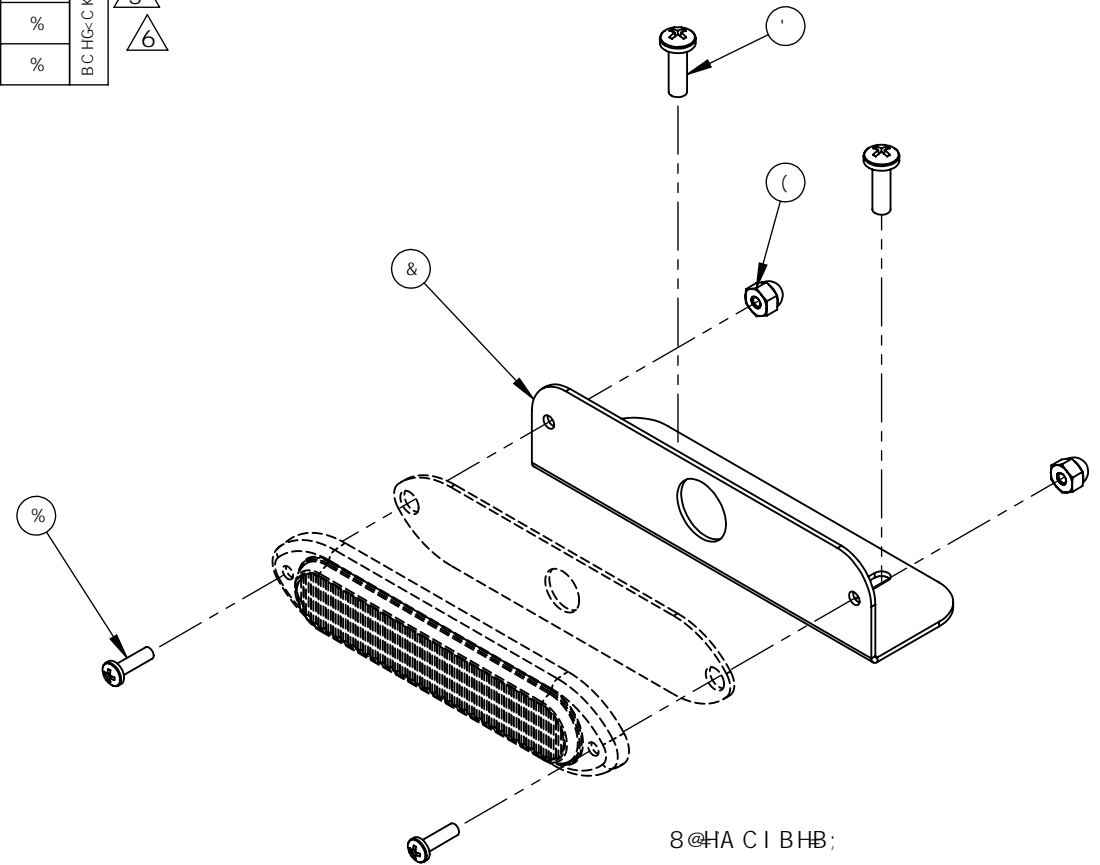
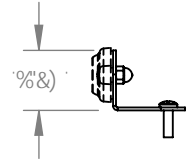
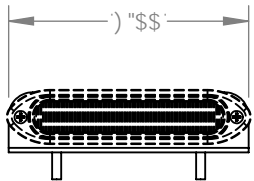
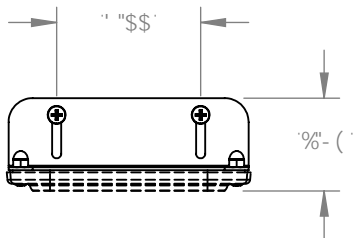

I B@GGCH 9FK -@9@97 ≠ 98	8F5K B'6M	A 8
8-A 9BGC BG5F9 B' B7 <9G	8F5K B; '5DDFCJ 98 6M97 F'	
.....HC @9F5B 7 9G~	H: 9 B: C FA 5HC B 7 C BH5 B 98 B H- G	
.....5B; I @5F, '± & 89, "	8F5K B: 'G H- 9GC @DFC D9F HMC:	
.....L± %\$	G5F < 958@ <H/ @5BHFB 7 C 'Z-B 7''	
.....LLL± '\$\$	5BMF9DFC 8I 7 HC B -B D5FHCF 5G5	
.....LLLL± '\$\$	K <C @K #K C I Hk- 9K F #H9B D9FA -GGC B	
.....LLLL± '\$\$%	C: G5F < 958@ <H/ @5BHFB 7 C 'Z-B 7'	
Fc<G7CA D@5BH M'g	'G GF 7 H@MDFC < 6#98"	
A 5HF-5@		
B #5		
: B G<		
B #5		

G5F < 958@ <H/ @5BHFB 7 C 'Z-B 7''	
() FcVAYgYfGh''5j cb BM%(((% D\ .f) ,) E&&*!-) '\$\$': UI .f) ,) E&&*!&\$&-	
AC 89@ &+(!8@HI	
H#9.	
8@H? #8F5K B;	
8K; "BC"	F9J
&+(!8@HI	6
G7 5 @. % (8C BCHG7 5 @. FCA 8F5K B: G< 99H% C : %