

ITEM NO.	PART NUMBER	DESCRIPTION	QTY.
1	S30150-489	DLIT WINDOW ADHESIVE BRACKET	1
2	P30052-18	6-32 x 3/8 PHILIPS PAN SCREW, S.S.	2
3	P401-4	3M TAPE (VHB 4979F)	.00174
*4	P30024-24	7" x 7" POLY BAG	1
*5	PLAB21X2WHI	KIT LABEL	1

REV.	ECR	DESCRIPTION	DATE
-	17192	INITIAL DRAWING REQUEST	03/26/2020

* NOT SHOWN

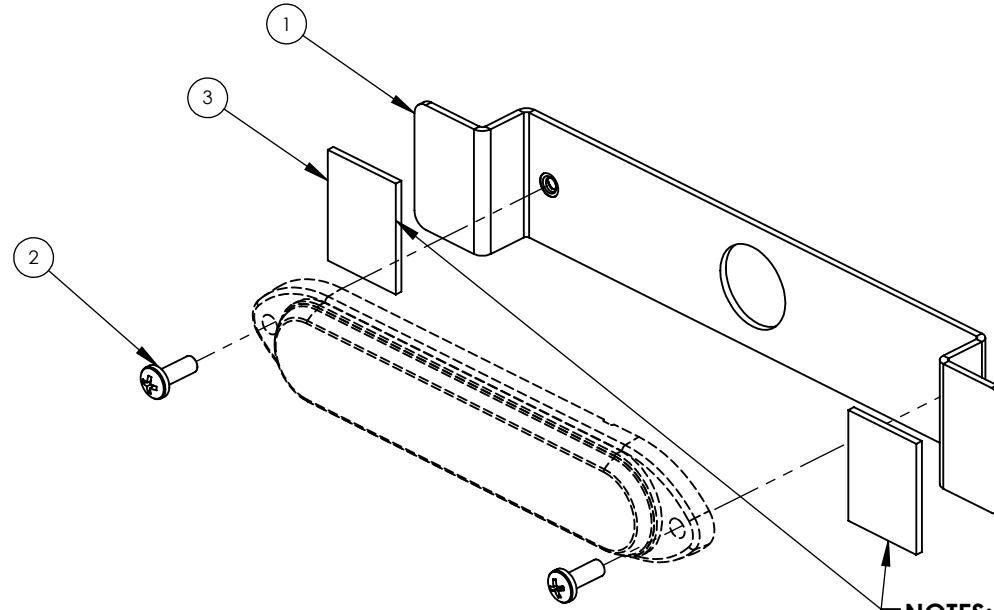

NOTES:

TAPE (3/4" LONG) TO BE INSTALLED BY ASSEMBLER.
LEAVE TAPE BACKING ON THE EXPOSED SIDE.

UNLESS OTHERWISE SPECIFIED DIMENSIONS ARE IN INCHES TOLERANCES: ANGULAR: ± 2 DEG. .X ± .100 .XX ± .020 .XXX ± .005 .XXXX ± .001	DRAWN BY: EP	STAR HEADLIGHT & LANTERN CO., INC. 455 Rochester St. Avon NY 14414 Ph:(585) 226-9500 Fax: (585) 226-2029
	DRAWING APPROVED BY ECR THE INFORMATION CONTAINED IN THIS DRAWING IS THE SOLE PROPERTY OF STAR HEADLIGHT & LANTERN CO., INC.. ANY REPRODUCTION IN PART OR AS A WHOLE WITHOUT THE WRITTEN PERMISSION OF STAR HEADLIGHT & LANTERN CO., INC. IS STRICTLY PROHIBITED.	
RoHS COMPLIANT: Yes	MODEL: 274-DLIT-W	TITLE: DLIT WINDOW ADHESIVE BRACKET
MATERIAL: N/A	DWG. NO. ADSVP-274-DLIT-W	REV -
FINISH: N/A	SCALE: 1:2	DO NOT SCALE FROM DRAWING SHEET 1 OF 1