

ITEM #	PART NUMBER	DESCRIPTION	QTY.
1	P30052-40	#6-32 x 1/2" PHILLIPS PAN TAPTITE S/S BLACK	2
2	P30150-469P	DLIT3 UNIVERSAL "L" BRACKET	1
3	P30054-23	#10 x 5/8" PHILLIPS PAN, TYPE 25, 401 S/S	2
4	P30092-7	#6-32 ACORN-LOW CROWN S/S BLACK	2
*5	P30024-24	7" x 7" POLY BAG	1
*6	PLAB21X2WHI	KIT LABEL	1
*7	PLIT544	INSTRUCTION	1

\* NOT SHOWN

REV.	ECR	DESCRIPTION	DATE
-	14238	INITIAL DRAWING REQUEST	03/30/2017

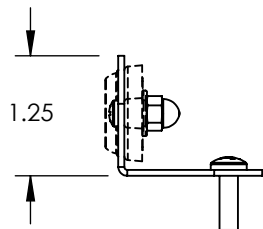
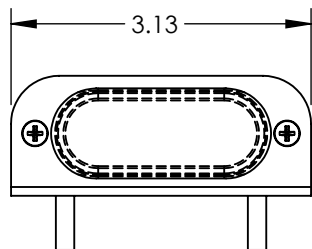
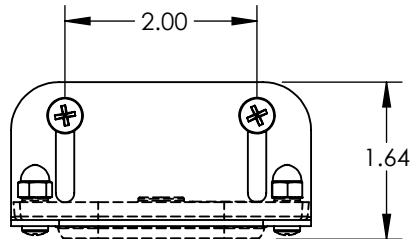
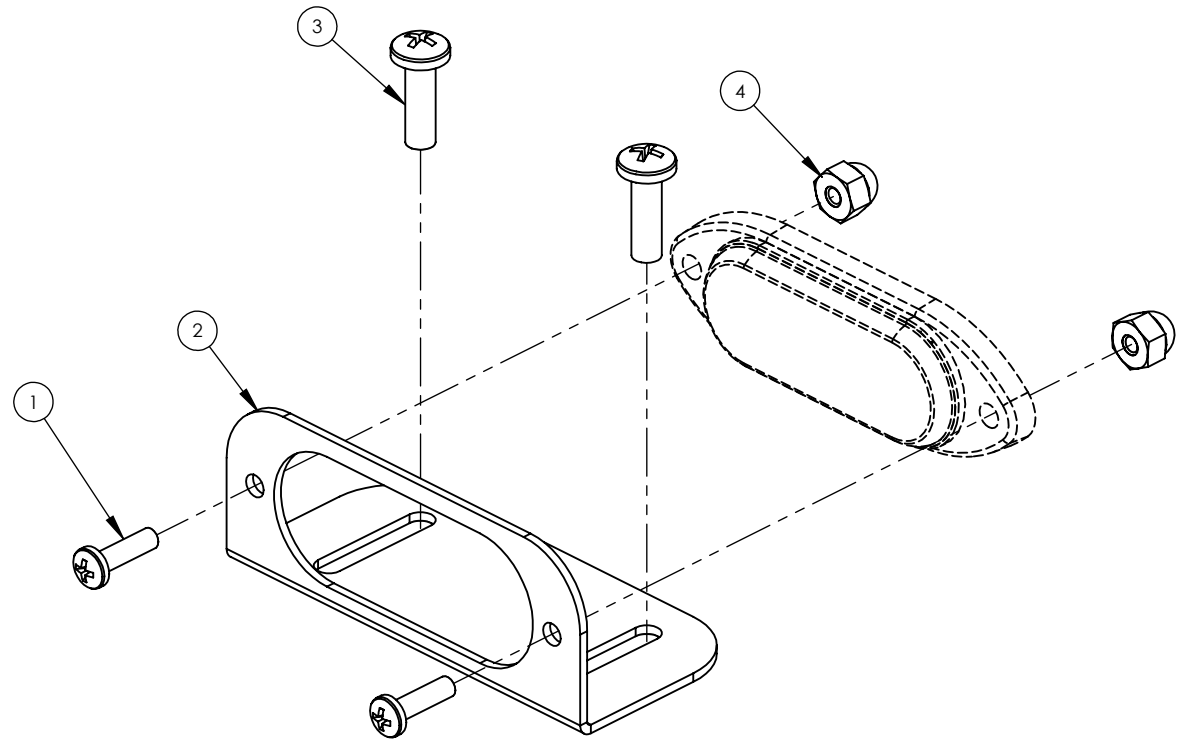

**UNLESS OTHERWISE SPECIFIED**  
 DIMENSIONS ARE IN INCHES  
 TOLERANCES:  
 ANGULAR:  $\pm 2$  DEG.  
 .X  $\pm .100$   
 .XX  $\pm .020$   
 .XXX  $\pm .005$   
 .XXXX  $\pm .001$

RoHS COMPLIANT: Yes

MATERIAL: N/A

FINISH: N/A

DRAWN BY: EP  
**DRAWING APPROVED BY ECR**

THE INFORMATION CONTAINED IN THIS DRAWING IS THE SOLE PROPERTY OF STAR HEADLIGHT & LANTERN CO., INC.. ANY REPRODUCTION IN PART OR AS A WHOLE WITHOUT THE WRITTEN PERMISSION OF STAR HEADLIGHT & LANTERN CO., INC. IS STRICTLY PROHIBITED.

**STAR HEADLIGHT & LANTERN CO., INC.**

455 Rochester St. Avon NY 14414  
 Ph:(585) 226-9500 Fax: (585) 226-2029

MODEL: 274-DLIT3-U

TITLE: DLIT3 UNIVERSAL "L" BRACKET KIT

DWG. NO. ADSVP-274-DLIT3-U

REV -

SCALE: 1:2 DO NOT SCALE FROM DRAWING SHEET 1 OF 1